



**SCORREVOLI PER PORTE IN VETRO
CON FERMO AMMORTIZZATO**

**SLIDING DOORS SYSTEM FOR GLASS,
WITH SOFT DAMPER STOPPERS**



Diva Air Vetro

Sliding system for glass doors with amortised stopper
Scorrevoli per porte in vetro con fermo ammortizzato

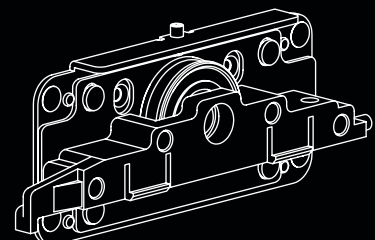

**SCORREVOLI PER PORTE IN VETRO
CON FERMO AMMORTIZZATO**

**SLIDING DOORS SYSTEM FOR GLASS,
WITH SOFT DAMPER STOPPERS**

N°	Barcode	Image	KG		N°	Barcode	Image	KG	
1	1478		40/80		7	1482		40/80	
	1473		40			8	1470		40/80
2	1477		80		9		1474		40/80
	1476/35G		40			10	1472		40/80
1476/80Y	80			11	1450			40/80	
4	1349/161		40/80			12	1486/8/10/12		40/80
	1484		40/80		13		1337		40/80
6	1341		40/80			14	1333		40/80

**SCORREVOLI PER PORTE IN VETRO
CON FERMO AMMORTIZZATO**

**SLIDING DOORS SYSTEM FOR GLASS,
WITH SOFT DAMPER STOPPERS**

CODE		KIT
1478/1349/P40/A 1478/1349/P40/B 1478/1349/P40/N 1478/1349/P40E3 1478/1349/P40AT	31 mm	



40 Kg



Classic stopper
Fermi a pinza



Patented system
Sistema brevettato



Anodized silver
Anodizzato argento



Electricolor black
Elettrocolore nero



Titanium steel
Acciaio titanio



Electricolor 3 (Coffee)
Elettrocolore 3 (Caffè)



Anodized bronze
Anodizzato bronzo

CODE		KIT
1478/1349/P80/A 1478/1349/P80/B 1478/1349/P80/N 1478/1349/P80E3 1478/1349/P80/AT	31 mm	



80 Kg



Classic stopper
Fermi a pinza



Patented system
Sistema brevettato



Anodized silver
Anodizzato argento



Electricolor black
Elettrocolore nero



Titanium steel
Acciaio titanio



Electricolor 3 (Coffee)
Elettrocolore 3 (Caffè)



Anodized bronze
Anodizzato bronzo

**SISTEMA INVISIBILE DI SCORREVOLI
PER PORTE IN VETRO**

**THE INVISIBLE SYSTEM
FOR SLIDING GLASS DOORS**



Magic Vetro

The invisible system for sliding glass doors
Sistema invisibile di scorrevoli per porte in vetro

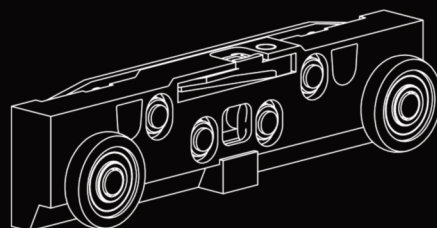

**SISTEMA INVISIBILE DI SCORREVOLI
PER PORTE IN VETRO**

**THE INVISIBLE SYSTEM
FOR SLIDING GLASS DOORS**

SCHEMA

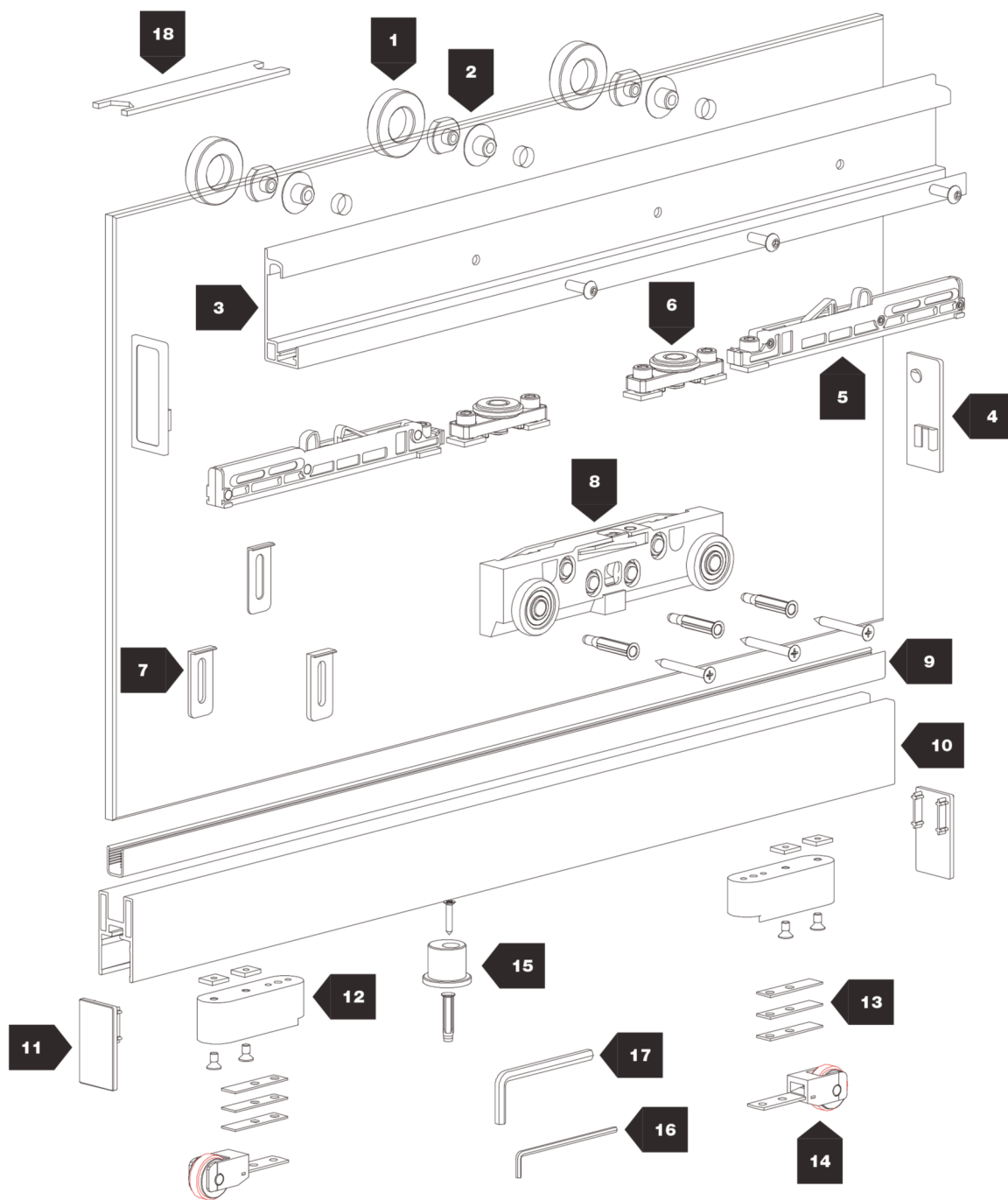

1100 mm ÷ 1800 mm



80 kg



10 mm

**SISTEMA INVISIBILE DI SCORREVOLI
PER PORTE IN VETRO**

**THE INVISIBLE SYSTEM
FOR SLIDING GLASS DOORS**

N°	Barcode	Image	KG		N°	Barcode	Image	KG	
1	2197		80			2192			
2	2195		80		10	2191		80	
3	2180		80			2201			
4	2186		80		11	2194		80	
5	2184		80		12	2178		80	
6	2183		80		13	2189/10		80	
	2179-01				14	2187/N		80	
7	2179-02		80		15	2196		80	
	2179-03				16	538		80	
8	2182		80		17	539		80	
9	2193		80		18	1164		80	

**SISTEMA INVISIBILE DI SCORREVOLI
PER PORTE IN VETRO**

**THE INVISIBLE SYSTEM
FOR SLIDING GLASS DOORS**

MISURE DI TAGLIO DEI PROFILI

MEASUREMENTS FOR PROFILES CUTTING

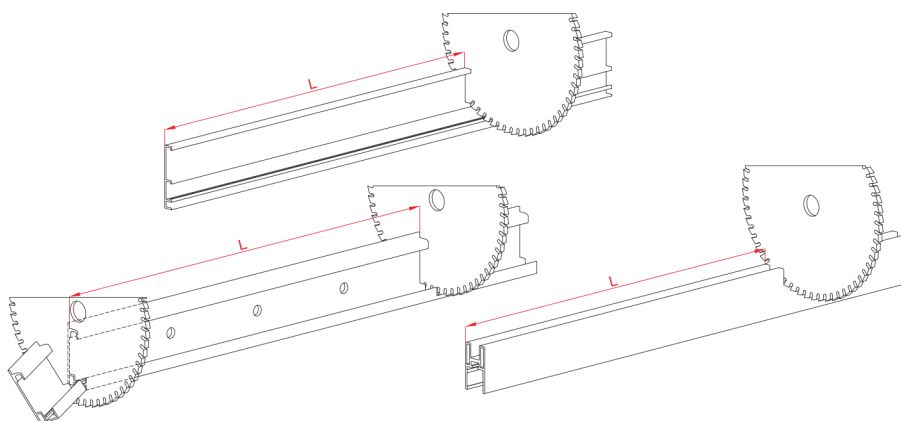
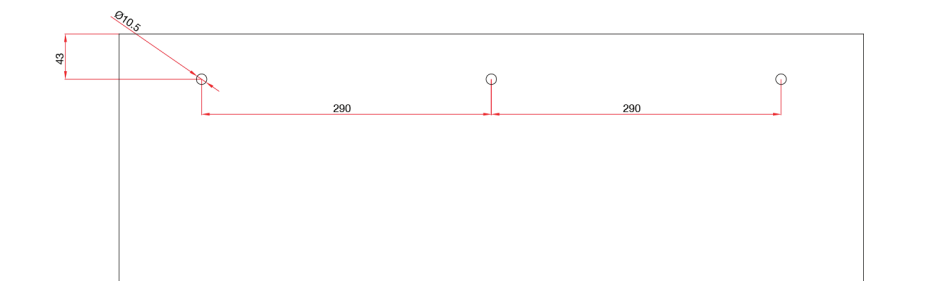

<p>ART. 2199</p>	<p>ART. 2198/A/1095 - ART. 2198/A/1795</p>	<p>ART. 2199</p>
<p>ART. 2186</p>	<p>ART. 2180/A/1095 - ART. 2180/A/1795</p>	<p>ART. 2186</p>

**SISTEMA INVISIBILE DI SCORREVOLI
PER PORTE IN VETRO**

**THE INVISIBLE SYSTEM
FOR SLIDING GLASS DOORS**

POSIZIONAMENTO DEGLI ACCESSORI

MEASUREMENTS FOR PROFILES CUTTING

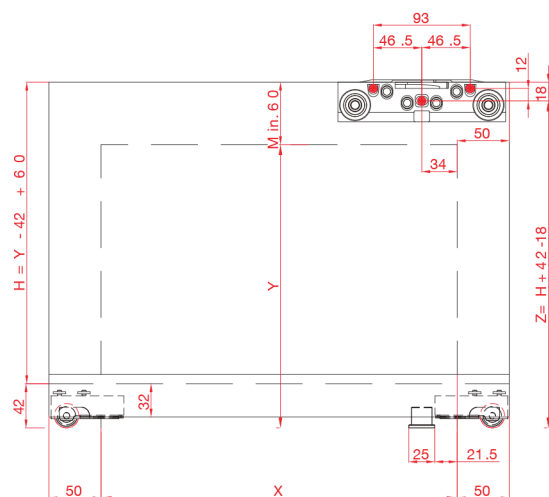
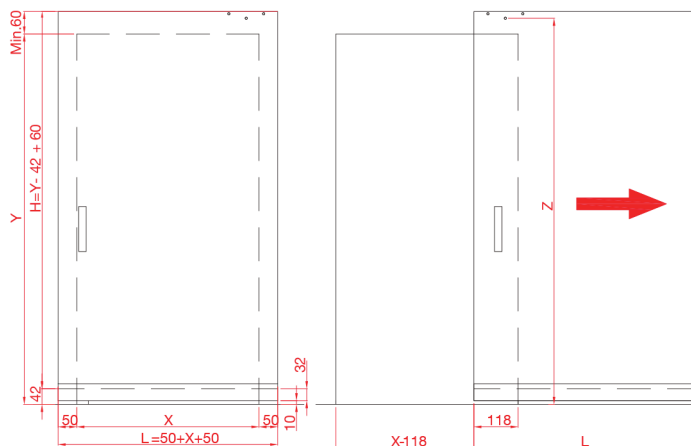

ART. MAGIC/1100
X= MIN. 700 (L=800)
X= MAX. 1000 (L=1100)

ART. MAGIC/1800
X= MIN. 700 (L=800)
X= MAX. 1700 (L=1800)

STANDARD POSITION / POSIZIONE STANDARD

PLACING ACCESSORIES / POSIZIONAMENTO DEGLI ACCESSORI

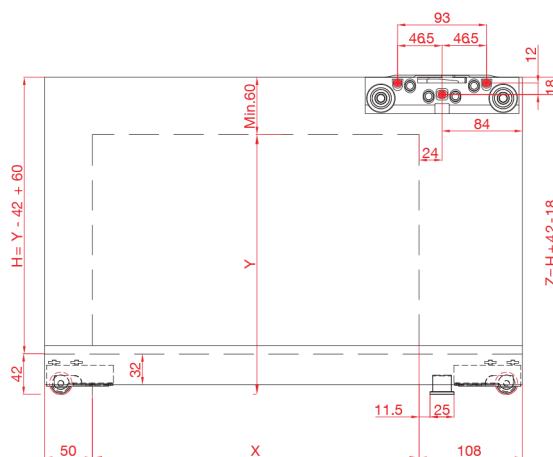
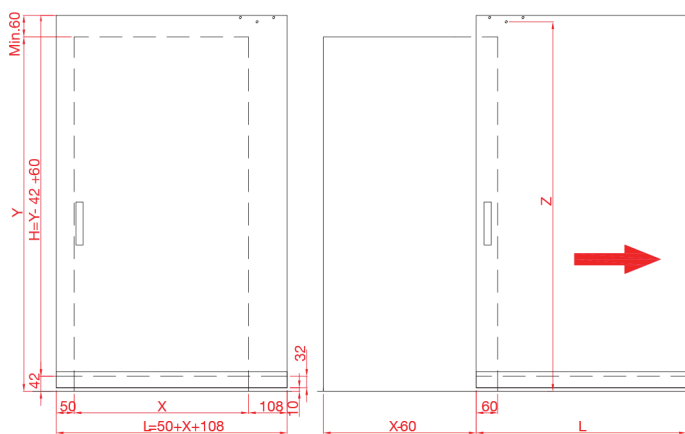

ART. MAGIC/1100
X= MIN. 700 (L=860)
X= MAX. 940 (L=1100)

ART. MAGIC/1800
X= MIN. 700 (L=860)
X= MAX. 1640 (L=1800)

**SISTEMA INVISIBILE DI SCORREVOLI
PER PORTE IN VETRO**

**THE INVISIBLE SYSTEM
FOR SLIDING GLASS DOORS**

POSIZIONAMENTO DEGLI ACCESSORI

MEASUREMENTS FOR PROFILES CUTTING

ACCESSORIES POSITIONING / POSIZIONAMENTO DEGLI ACCESSORI

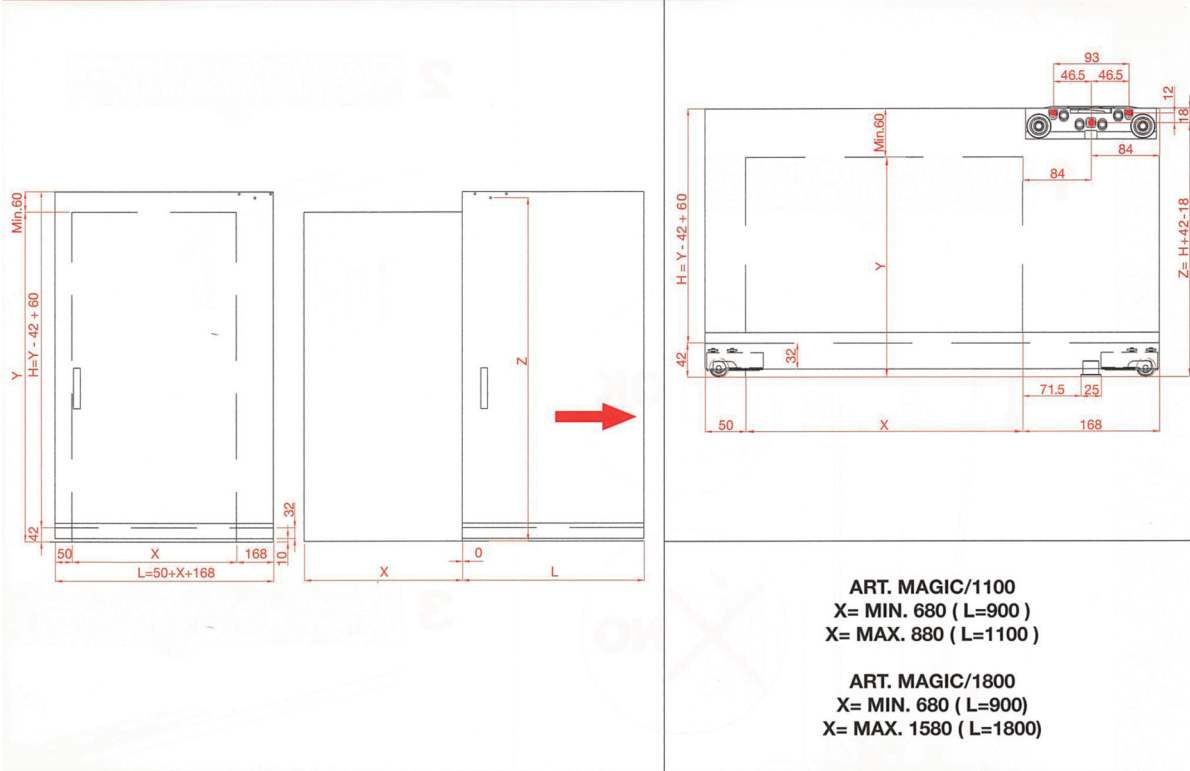

TOTAL OPENING POSITION / POSIZIONE APERTURA TOTALE

MEASUREMENTS DESCRIPTION / DESCRIZIONE DELLE MISURE

